

Ventomat®

Ventilateurs à grand débit pour le séchage du foin



Encombresments - Performances



Karl Barth AG
Unterdorf 27
CH- 8421 Dättlikon

Tel. +41 52 301 00 13
E-mail info@kbarth.ch
Internet www.kbarth.ch

Version: 20.09.2022

Tableau de performances pour ventilateurs à grand débit Ventomat

| | | à aspiration unilatérale | | | | | | | | | | | | | | | | | | | | | | | |
|------------|-------------|--------------------------|--------|------|------------------------------|------------------|--------------------|--------------------|-------------------|--------------------|--------------------|-------------------|-------------------|-------------------|-------------------|-------------------|-------------------|--------------------|-------------------|-------------------|-------------------|--------------|-------|-------|--|
| FAT | Ventomat | Moteur | Taille | | mbar | 2 | 3 | 4 | 5 | 6 | 7 | 8 | 90 | 100 | 110 | 120 | 130 | 140 | 160 | 180 | 200 | Pression max | Bruit | | |
| N° de test | Type | Type | KW | CV | mmCE | 20 | 30 | 40 | 50 | 60 | 70 | 80 | 90 | 100 | 110 | 120 | 130 | 140 | 160 | 180 | 200 | mbar | dB(A) | | |
| | SE-1-60-4p | 3SIE 100 LB 4 | 3.0 | 4.0 | m3/s KW % | | | 1.9 3.0 25 | 1.8 3.0 29 | 1.7 3.0 34 | 1.6 3.1 37 | 1.5 3.2 38 | 1.4 3.2 41 | 1.3 3.2 41 | 1.2 3.3 40 | 1.0 3.4 35 | 0.7 3.2 29 | | | | | 13.9 | | | |
| | SE-1-100-4p | 3SIE 112 M 4 | 4.0 | 5.5 | m3/s KW % | | | 3.7 4.9 28 | 3.5 5.0 35 | 3.4 5.0 41 | 3.3 4.9 42 | 3.2 4.8 53 | 3.0 4.7 57 | 2.8 4.6 61 | 2.6 4.4 68 | 2.4 4.2 69 | 2.1 4.1 67 | 1.8 4.0 63 | | | | 14.2 | | | |
| 529 | SE | 3SIE 132 S 6 | 3.0 | 4.0 | m3/s KW % | 5.3 3.6 30 | 5.1 3.8 41 | 4.8 3.9 49 | 4.4 4.0 55 | 4.0 4.0 60 | 3.5 4.0 61 | 3.0 3.9 61 | 2.2 3.2 55 | | | | | | | | | 9.5 | 61/65 | | |
| 285 | SE | 3SIE 132 MA 6 | 4.0 | 5.5 | m3/s KW % | 5.8 4.3 27 | 5.6 4.4 38 | 5.3 4.5 46 | 4.8 4.5 53 | 4.4 4.5 58 | 3.9 4.5 60 | 3.3 4.3 62 | 2.7 4.0 59 | | | | | | | | | 9.6 | 69/73 | | |
| 1950 | SE-B | 3SIE 132 S 4 | 5.5 | 7.5 | m ³ /s KW % | 5.0 4.2 22 | 4.8 4.4 30.5 | 4.7 4.7 38.4 | 4.5 4.9 45 | 4.1 5.1 50.7 | 3.6 4.2 55.3 | 3.0 5.5 61 | 2.3 3.8 61 | | | | | 2.6 6.1 58.0 | | | | 15.8 | 68/69 | | |
| 1081 | SE-2 | 3SIE 132 S 6 | 3.0 | 4.0 | m3/s KW % | 5.5 3.3 33 | 5.2 3.5 45 | 4.9 3.6 54 | 4.5 3.8 59 | 4.1 3.9 63 | 3.6 3.9 64 | 3.0 3.8 64 | 2.3 3.5 62 | | | | | | | | | 9.6 | 65/70 | | |
| 1082 | SE-2 | 3SIE 132 MA 6 | 4.0 | 5.5 | m3/s KW % | 6.3 4.3 29 | 6.0 4.5 40 | 5.7 4.6 49 | 5.4 4.7 58 | 4.9 4.6 63 | 4.5 4.7 66 | 4.0 4.7 68 | 3.5 4.1 67 | 2.0 3.1 54 | | | | | | | | 10.1 | 67/69 | | |
| 530 | SE-2 | 3SIE 132 MB 6 | 5.5 | 7.5 | m3/s KW % | 7.6 6.0 25 | 7.2 6.2 35 | 6.5 6.1 43 | 6.0 6.1 50 | 5.4 6.1 54 | 4.8 6.0 56 | 4.1 5.8 57 | 3.6 5.5 56 | | | | | | | | | 10.0 | 68/70 | | |
| 1951 | SE-2B | 3SIE 132 M 4 | 7.5 | 10.0 | m ³ /s KW % | 6.4 5.5 45 | 6.3 5.9 48 | 6.1 6.2 50 | 5.9 6.5 53 | 5.7 6.8 55 | 5.5 7.1 57 | 5.3 7.3 59 | 5.1 7.5 60 | 4.8 7.8 62 | 4.6 7.9 63 | 4.3 8.1 63 | 4.0 8.2 63 | 3.6 8.2 62 | 2.6 7.7 55 | | | 16.4 | 70/74 | | |
| 1965 | SE-2BH | 3SIE 160 MA 4 | 11.0 | 15.0 | m ³ /s KW % | 8.1 8.8 17 | 7.9 9.1 24 | 7.7 9.4 30 | 7.5 9.7 35 | 7.4 10.0 41 | 7.2 10.3 45 | 7.0 10.6 50 | 6.8 10.8 54 | 6.5 11.1 57 | 6.3 11.3 60 | 6.1 11.5 63 | 5.9 11.6 65 | 5.5 11.7 66 | 4.9 11.7 67 | 4.0 11.3 64 | | | 19.3 | 71/74 | |
| 1933 | RE-2-160-4p | 3SIE 132 S 4 | 5.5 | 7.5 | m3/s KW % | 5.6 4.6 25 | 5.4 4.8 32 | 5.2 5.0 39 | 4.9 5.2 46 | 4.7 5.3 51 | 4.4 5.4 56 | 4.1 5.5 60 | 3.8 5.6 63 | 3.4 5.6 64 | 2.9 5.5 61 | 2.3 5.2 53 | | | | | | | 12.2 | 68/71 | |
| 1964 | SE-2-120-4p | 3SIE 132 M 4 | 7.5 | 10.0 | m3/s KW % | 5.7 4.7 29 | 5.5 5.0 34 | 5.3 5.3 38 | 5.2 5.7 43 | 5.0 5.9 47 | 4.8 6.2 50 | 4.6 6.5 54 | 4.4 6.7 57 | 4.2 6.9 59 | 4.0 7.1 62 | 3.8 7.2 63 | 3.5 7.3 64 | 3.3 7.4 64 | 2.7 7.3 62 | 2.0 6.8 52 | | | 18.7 | 71/74 | |
| | SE-2-150-4p | 3SIE 160 MA 4 | 10.0 | 13.5 | m3/s KW % | | | 6.7 6.8 40 | 6.5 7.1 43 | 6.3 7.4 47 | 6.0 7.8 50 | 5.8 8.1 54 | 5.5 8.3 56 | 5.3 8.6 59 | 5.1 8.8 61 | 4.8 9.0 63 | 4.5 9.2 64 | 4.1 9.3 64 | 3.4 9.1 62 | 2.5 8.5 54 | | | 19.2 | | |
| | SE-2-175-4p | 3SIE 160 MA 4 | 11.0 | 15.0 | m3/s KW % | | | | 7.9 11.1 35 | 7.7 11.4 40 | 7.5 11.6 45 | 7.3 11.8 49 | 7.0 12.0 53 | 6.8 12.2 55 | 6.6 12.4 58 | 6.4 12.6 60 | 6.1 12.8 62 | 5.8 13.0 63 | 5.3 13.0 64 | 4.6 12.8 64 | 3.7 11.5 58 | | | 22.2 | |

Tableau de performances pour ventilateurs à grand débit Ventomat

| | | à aspiration unilatérale | | | | | | | | | | | | | | | | | | Bruit | | | | |
|------------|---------------|--------------------------|--------|------|-----------------|--------------------|--------------------|--------------------|--------------------|--------------------|--------------------|--------------------|--------------------|--------------------|--------------------|--------------------|--------------------|--------------------|-------------------|-------------------|-------------------|-------------------|-------|-------|
| FAT | Ventomat | Moteur | Taille | mbar | 2 | 3 | 4 | 5 | 6 | 7 | 8 | 90 | 100 | 110 | 120 | 130 | 140 | 160 | 180 | 200 | Pression max | Bruit | | |
| N° de test | Type | Type | KW | CV | mmCE | 20 | 30 | 40 | 50 | 60 | 70 | 80 | 90 | 100 | 110 | 120 | 130 | 140 | 160 | 180 | 200 | mbar | dB(A) | |
| 1083 | SE-3 | 3SIE 132 MB 6 | 5.5 | 7.5 | m3/s KW % | 9.1 5.0 37 | 8.5 5.5 47 | 7.9 5.9 54 | 7.3 6.2 59 | 6.5 6.3 62 | 5.9 6.5 63 | 5.2 6.6 64 | 4.4 6.4 59 | 1.5 4.4 33 | | | | | | | | | 10.1 | 65/68 |
| 1923 | SE-3K | 3SIE 132 MB 6 | 5.5 | 7.5 | m3/s KW % | 8.3 4.5 39 | 7.9 4.9 45 | 7.5 5.3 51 | 7.0 5.6 57 | 6.5 5.9 61 | 5.9 6.2 65 | 5.3 6.3 67 | 4.7 6.4 67 | 3.9 6.2 65 | 2.9 5.8 57 | 1.5 4.6 37 | | | | | | | 12.1 | 63/67 |
| 1772 | SE-3 | 3SIE 160 M 6 | 7.5 | 10.0 | m3/s KW % | 9.8 5.6 40 | 9.3 6.0 47 | 8.8 6.4 53 | 8.3 6.8 58 | 7.7 7.1 63 | 7.0 7.3 66 | 6.3 7.4 68 | 5.6 7.4 69 | 4.7 7.3 66 | 3.6 6.8 60 | 2.1 5.6 43 | | | | | | | 12.3 | 66/68 |
| 1849 | SE-3G | 3SIE 160 M 6 | 7.5 | 10.0 | m3/s KW % | 9.2 5.8 32 | 8.9 6.3 39 | 8.5 6.7 45 | 8.1 7.1 51 | 7.6 7.4 56 | 7.2 7.7 61 | 6.7 8.0 65 | 6.1 8.1 68 | 5.5 8.2 69 | 4.7 8.1 68 | 3.8 7.6 63 | 2.3 6.3 47 | | | | | | 13.1 | 68/74 |
| 1966 | SE-3G-215-6p | 3SIE 160 L 6 | 11.0 | 15.0 | m3/s KW % | 12.4 10.9 27 | 11.9 11.3 33 | 11.5 11.7 38 | 11.0 12.0 44 | 10.5 12.3 48 | 10.0 12.3 52 | 9.5 12.7 57 | 8.9 12.8 61 | 8.2 12.8 64 | 8.2 12.8 64 | 7.4 12.6 66 | 6.6 12.2 66 | 5.5 11.5 65 | 3.9 9.8 57 | 8.1 19.8 66 | 7.4 20.0 65 | 6.5 20.1 64 | 14.4 | 73/74 |
| | SE-3GH-160-4p | 3SIE 180 M 4 | 18.5 | 25.0 | m3/s KW % | | | | 11.1 15.5 48 | 10.8 15.9 50 | 10.6 16.3 52 | 10.4 16.7 54 | 10.2 17.1 56 | 10.0 17.5 57 | 9.6 18.1 58 | 9.2 18.6 59 | 9.0 18.9 62 | 8.8 19.1 64 | 8.1 19.8 66 | 7.4 20.0 66 | 6.5 20.1 64 | 25.0 | 85 | |
| | SE-3GH-190-4p | 3SIE 180 L 4 | 22.0 | 30.0 | m3/s KW % | | | | 12.4 17.0 48 | 12.2 17.6 50 | 12.0 18.2 51 | 11.8 18.8 53 | 11.6 19.4 55 | 11.3 19.8 57 | 11.0 20.5 59 | 10.7 21.0 61 | 10.4 21.6 62 | 10.1 22.2 64 | 9.5 22.9 66 | 8.7 23.6 68 | 7.9 23.7 67 | 25.5 | 85 | |
| | RE-3G-148-4p | 3SIE 160 MA 4 | 10.0 | 13.5 | m3/s KW % | | | | 9.8 9.7 44 | 9.4 10.3 48 | 9.0 10.7 53 | 8.6 11.1 60 | 8.2 11.5 64 | 7.8 11.7 64 | 7.3 11.9 66 | 6.8 12.0 67 | 6.3 12.1 69 | 5.7 12.0 68 | | | | | 16.9 | |
| | RE-3G-148-4p | 3SIE 160 L 4 | 15.0 | 20.0 | m3/s KW % | | | | 11.4 13.6 39 | 11.2 14.2 42 | 10.8 14.7 45 | 10.6 15.2 49 | 10.2 15.7 53 | 9.9 16.1 56 | 9.5 16.5 59 | 9.2 17.0 62 | 8.7 17.3 64 | 8.4 17.5 66 | 7.5 17.8 69 | 6.4 17.7 68 | 4.9 16.5 63 | 21.8 | | |
| 1161 | SE-4 | 3SIE 160 M 6 | 7.5 | 10.0 | m3/s KW % | 11.0 6.4 34 | 10.5 7.1 45 | 9.9 7.7 52 | 9.3 8.1 57 | 8.6 8.4 62 | 7.8 8.5 65 | 7.2 8.7 66 | 6.5 8.8 66 | 5.9 8.8 65 | 4.8 8.4 61 | 2.2 6.5 41 | | | | | | | 12.3 | 66/70 |
| 1517 | SE-4 | 3SIE 160 L 6 | 11.0 | 15.0 | m3/s KW % | 12.8 9.5 27 | 12.4 10.3 36 | 11.9 10.9 43 | 11.4 11.6 49 | 10.9 12.1 54 | 10.4 12.5 58 | 9.9 12.8 62 | 9.2 12.7 65 | 8.4 12.7 66 | 8.4 12.7 66 | 7.5 12.7 67 | 6.8 12.5 66 | 5.5 11.7 62 | 3.3 9.0 51 | | | | 14.1 | 71/74 |
| 1930 | SE-4-300-6p | 3SIE 180 L 6 | 15.0 | 20.0 | m3/s KW % | 14.7 13.5 26 | 14.2 14.0 31 | 13.7 14.4 36 | 13.2 14.8 41 | 12.7 15.1 46 | 12.2 15.4 50 | 11.6 15.6 55 | 10.9 15.8 58 | 10.2 15.9 62 | 9.4 15.8 64 | 8.5 15.5 66 | 7.4 14.9 66 | 5.9 13.6 63 | 5.9 13.6 63 | | | | 14.7 | 73/78 |
| 1922 | RE-4-255-4p | 3SIE 180 M 4 | 18.5 | 25.0 | m3/s KW % | | | | 14.4 18.0 37 | 13.5 18.5 41 | 13.0 18.8 45 | 12.6 19.2 48 | 12.0 19.5 52 | 11.5 19.7 55 | 10.9 19.8 57 | 10.3 19.8 60 | 9.5 19.7 62 | 8.8 19.5 63 | 6.8 18.0 62 | 6.8 18.0 62 | | | 17.5 | 76/81 |

Tableau de performances pour ventilateurs à grand débit Ventomat

| | | à aspiration bilatérale | | | | | | | | | | | | | | | | | | | | | | |
|------------|----------|-------------------------|--------|------|-----------------|--------------------|--------------------|--------------------|--------------------|--------------------|--------------------|--------------------|--------------------|--------------------|--------------------|--------------------|-------------------|---------------------|---------------------|------|------|--------------|-------|-------|
| FAT | Ventomat | Moteur | Taille | | mbar | 2 | 3 | 4 | 5 | 6 | 7 | 8 | 9.0 | 10.0 | 11.0 | 12.0 | 13.0 | 14.0 | 16.0 | 18.0 | 20.0 | Pression max | Bruit | |
| N° de test | Type | Type | KW | CV | mmCE | 20 | 30 | 40 | 50 | 60 | 70 | 80 | 90 | 100 | 110 | 120 | 130 | 140 | 160 | 180 | 200 | mbar | dB(A) | |
| 1084 T | R-2 K | 3SIE 112 M 4 | 4.0 | 5.5 | m3/s KW % | 9.2 4.6 40 | 8.4 4.7 53 | 7.3 4.8 61 | 6.0 4.7 64 | 4.1 4.2 58 | | | | | | | | | | | | | 6.3 | 63/65 |
| 1084 | R-2 K | 3SIE 132 S 4 | 5.5 | 7.5 | m3/s KW % | 10.6 6.1 35 | 9.8 6.4 46 | 9.0 6.4 56 | 8.0 6.6 61 | 6.9 6.5 64 | 5.4 6.1 62 | | | | | | | | | | | | 7.7 | 65/67 |
| 1085 | R-2 K | 3SIE 132 M 4 | 7.5 | 10.0 | m3/s KW % | 12.3 8.3 30 | 11.7 8.7 40 | 11.1 9.1 49 | 10.3 9.1 57 | 9.4 9.2 61 | 8.5 9.2 64 | 7.4 9.1 65 | 6.0 8.7 62 | | | | | | | | | | 9.9 | 69/71 |
| 1085 H | R-2 K | 3SIE 160 MA 4 | 10.0 | 13.5 | m3/s KW % | 13.5 10.3 26 | 12.9 10.9 36 | 12.4 11.2 44 | 11.8 11.7 51 | 11.0 11.5 57 | 10.2 11.7 61 | 9.3 11.7 64 | 8.3 11.6 65 | 7.3 11.3 64 | 4.1 8.4 53 | | | | | | | | 11.6 | 71/73 |
| | R-2 K | 3SIE 160 MA 4 | 11.0 | 15.0 | m3/s KW % | 13.8 10.8 25 | 13.2 11.1 35 | 12.6 11.7 43 | 12.0 12.0 51 | 11.4 12.1 57 | 10.7 12.3 59 | 9.9 12.4 62 | 9.0 12.3 64 | 8.0 12.1 65 | 6.7 11.6 63 | 2.8 7.4 45 | | | | | | | 12.0 | |
| | R-2 K | 3SIE 160 L 4 | 15.0 | 20.0 | m3/s KW % | 15.0 15.2 29 | 14.5 15.7 29 | 14.5 15.7 37 | 14.0 16.1 43 | 13.5 16.5 50 | 12.8 16.6 55 | 12.3 16.8 59 | 11.6 16.9 61 | 10.9 17.0 63 | 10.0 16.8 64 | 9.2 16.7 65 | 7.9 16.1 63 | | | | | | 14.8 | |
| 1515 T | R-3 L | 3SIE 112 M 4 | 4.0 | 5.5 | m3/s KW % | 9.1 3.8 48 | 8.2 4.3 57 | 7.3 4.7 62 | 6.2 5.0 62 | 4.8 5.0 58 | 1.8 3.7 33 | | | | | | | | | | | | 7.1 | 62/64 |
| 1515 K | R-3 L | 3SIE 132 S 4 | 5.5 | 7.5 | m3/s KW % | 10.1 4.5 44 | 9.3 5.2 54 | 8.4 5.7 59 | 7.5 6.1 62 | 6.5 6.3 62 | 5.2 6.3 58 | 2.8 5.3 42 | | | | | | | | | | | 8.3 | 64/66 |
| 1516 U | R-3 L | 3SIE 132 M 4 | 7.5 | 10.0 | m3/s KW % | 11.6 5.9 39 | 11.0 6.6 50 | 10.2 7.3 57 | 9.5 7.7 61 | 8.7 8.2 64 | 7.9 8.6 64 | 6.9 8.8 63 | 5.6 8.5 58 | 3.6 7.5 47 | | | | | | | | | 10.4 | 67/69 |
| 1516 T | R-3 L | 3SIE 160 MA 4 | 9.5 | 12.6 | m3/s KW % | 12.7 7.2 36 | 12.1 8.0 46 | 11.6 8.7 53 | 10.8 9.4 58 | 10.1 9.9 61 | 9.4 10.4 63 | 8.7 10.8 64 | 7.6 11.1 64 | 6.8 11.0 61 | 5.4 10.6 55 | 2.2 8.1 33 | | | | | | | 12.2 | 69/71 |
| 1516 K | R-3 L | 3SIE 160 MA 4 | 11.0 | 15.0 | m3/s KW % | 13.2 7.8 34 | 12.7 8.6 44 | 12.1 9.4 51 | 11.5 10.2 56 | 10.8 10.7 60 | 10.1 11.3 63 | 9.4 11.7 64 | 8.6 12.1 64 | 7.7 12.2 62 | 6.6 12.1 60 | 5.3 11.8 54 | 1.3 7.6 23 | | | | | | 13.0 | 70/72 |
| | R-3 L | 3SIE 160 L 4 | 15.0 | 20.0 | m3/s KW % | 14.9 10.3 35 | 14.5 11.4 40 | 14.0 12.5 44 | 13.5 13.3 48 | 12.9 14.1 52 | 12.4 14.9 55 | 11.8 15.4 57 | 11.2 16.0 60 | 10.5 16.3 62 | 9.8 16.7 64 | 9.0 16.9 65 | 8.2 17.0 64 | 6.0 16.6 60.0 | 3.5 14.0 40.0 | | | | 16.3 | |
| | R-3 L | 3SIE 180 M 4 | 18.5 | 25.0 | m3/s KW % | 14.9 13.9 45 | 14.9 13.9 45 | 14.9 13.9 45 | 14.3 14.6 49 | 13.8 15.5 52 | 13.3 16.2 57 | 12.8 17.0 60 | 12.2 17.8 61 | 11.6 18.2 63 | 11.0 18.7 64 | 10.2 19.2 64 | 9.4 19.3 64 | 8.5 19.4 62.0 | 6.3 18.5 56.0 | | | | 17.7 | |

Tableau de performances pour ventilateurs à grand débit Ventomat

| | | à aspiration bilatérale | | | | | | | | | | | | | | | | | | Bruit | | | | |
|------------|----------|-------------------------|--------|------|-----------------|--------------------|--------------------|--------------------|--------------------|--------------------|--------------------|--------------------|--------------------|--------------------|--------------------|--------------------|--------------------|--------------------|--------------------|--------------------|-------------------|--------------|-------|-------|
| FAT | Ventomat | Moteur | Taille | | mbar | 2 | 3 | 4 | 5 | 6 | 7 | 8 | 9.0 | 10.0 | 11.0 | 12.0 | 13.0 | 14.0 | 16.0 | 18.0 | 20.0 | Pression max | Bruit | |
| N° de test | Type | Type | KW | CV | mmCE | 20 | 30 | 40 | 50 | 60 | 70 | 80 | 90 | 100 | 110 | 120 | 130 | 140 | 160 | 180 | 200 | mbar | dB(A) | |
| 1069 T | R-3 K | 3SIE 132 S 4 | 5.5 | 7.5 | m3/s KW % | 12.2 5.8 42 | 11.0 6.2 54 | 9.7 6.2 62 | 8.3 6.3 65 | 6.5 6.1 64 | 3.7 5.2 50 | | | | | | | | | | | | 7.4 | 60/62 |
| 1069 | R-3 K | 3SIE 132 M 4 | 7.5 | 10.0 | m3/s KW % | 14.3 8.0 36 | 13.3 8.5 47 | 12.3 8.9 55 | 11.0 8.9 62 | 9.8 9.1 65 | 8.5 9.1 65 | 6.7 8.6 62 | | | | | | | | | | | 9.4 | 63/65 |
| 928 T | R-3 K | 3SIE 160 MA 4 | 10.0 | 13.5 | m3/s KW % | 16.4 10.0 33 | 15.4 10.8 43 | 14.4 11.3 51 | 13.5 11.7 58 | 12.2 11.8 62 | 11.1 11.9 65 | 10.0 11.9 67 | 8.7 11.9 66 | 7.0 11.3 62 | 4.0 9.4 55 | | | | | | | | 11.5 | 66/68 |
| 928 | R-3 K | 3SIE 160 MA 4 | 11.0 | 15.0 | m3/s KW % | 17.1 10.9 31 | 16.1 11.8 41 | 15.1 12.2 49 | 14.2 12.7 56 | 13.0 12.9 60 | 11.9 13.0 64 | 10.9 13.1 67 | 9.1 12.9 66 | 8.1 12.6 64 | 6.0 11.6 57 | | | | | | | | 12.2 | 67/69 |
| 1926K | R-3 K | 3SIE 160 L 4 | 15.0 | 20.0 | m3/s KW % | 18.5 13.8 32 | 17.7 14.4 38 | 17.0 15.1 44 | 16.2 15.6 49 | 15.3 16.1 54 | 14.5 16.6 58 | 13.5 16.9 62 | 12.5 17.1 65 | 11.4 17.2 66 | 10.2 17.1 67 | 7.3 15.9 61 | 5.2 14.4 51 | | | | | | 14.6 | 69/71 |
| 1925K | R-3 K | 3SIE 180 M 4 | 18.5 | 25.0 | m3/s KW % | 20.1 16.7 28 | 19.4 17.4 34 | 18.7 18.1 39 | 18.0 18.7 45 | 17.3 19.3 50 | 16.5 19.8 54 | 15.7 20.3 58 | 14.8 20.6 62 | 13.9 20.9 65 | 13.0 21.1 67 | 9.4 20.9 68 | 5.9 18.0 53 | | | | | | 16.8 | 70/74 |
| 1924K | R-3 K | 3SIE 180 L 4 | 22.0 | 30.0 | m3/s KW % | 21.5 19.9 28 | 20.9 20.6 33 | 20.3 21.3 38 | 19.7 22.0 42 | 19.0 22.6 47 | 18.3 23.2 51 | 17.6 23.7 55 | 16.9 24.2 58 | 16.1 24.6 62 | 15.3 24.9 64 | 14.4 25.1 67 | 14.4 25.1 67 | 13.5 25.3 68 | 12.5 25.2 69 | 10.1 24.6 68 | 6.9 22.3 57 | | 19.3 | 73/77 |
| 1086 U | R-4 K | 3SIE 200 L 4 | 30.0 | 40.0 | m3/s KW % | 16.4 7.7 42 | 15.0 8.3 54 | 13.4 8.7 62 | 11.8 9.0 65 | 10.3 9.1 68 | 8.4 8.8 67 | | | | | | | | | | | | 8.0 | 63/64 |
| 1086 T | R-4 K | 3SIE 160 MA 4 | 10.0 | 13.5 | m3/s KW % | 18.7 10.1 37 | 17.4 10.8 48 | 16.1 11.4 57 | 14.6 11.8 62 | 13.1 12.1 65 | 11.8 12.2 68 | 10.3 12.0 66 | 6.6 10.5 56 | | | | | | | | | | 9.7 | 65/66 |
| 1086 | R-4 K | 3SIE 160 MA 4 | 11.0 | 15.0 | m3/s KW % | 19.4 10.9 36 | 18.2 11.7 47 | 16.9 12.3 55 | 15.5 12.7 61 | 14.1 13.1 64 | 12.7 13.3 67 | 11.3 13.3 68 | 9.4 12.8 66 | 3.0 9.3 32 | | | | | | | | | 10.3 | 66/67 |
| 1086 H | R-4 K | 3SIE 160 L 4 | 15.0 | 20.0 | m3/s KW % | 22.0 14.5 30 | 20.9 15.3 41 | 19.8 16.1 49 | 18.6 16.8 55 | 17.3 17.2 61 | 16.1 17.7 64 | 14.8 18.0 66 | 13.5 18.1 67 | 12.2 17.9 67 | 10.6 17.5 66 | 5.2 13.8 44 | | | | | | | 12.6 | 68/69 |
| 1934 | R-4 K | 3SIE 180 M 4 | 18.5 | 25.0 | m3/s KW % | 23.3 16.9 40 | 21.5 17.9 45 | 20.7 18.8 49 | 19.8 19.7 53 | 18.9 20.5 57 | 17.9 21.3 60 | 16.8 22.0 63 | 15.7 22.6 66 | 14.5 23.1 68 | 13.1 23.4 69 | 11.5 23.5 69 | 9.4 20.3 62 | 6.4 18.2 50 | | | | | 14.3 | 70/73 |
| 1935 | R-4 K | 3SIE 180 L 4 | 22.0 | 30.0 | m3/s KW % | 23.3 16.9 40 | 22.5 17.9 45 | 21.7 18.8 49 | 20.9 19.7 53 | 20.0 20.5 57 | 19.1 21.3 60 | 18.2 22.0 63 | 17.1 22.6 66 | 16.0 23.1 68 | 14.8 23.4 69 | 13.4 23.5 69 | 11.8 23.2 68 | 9.9 22.5 63 | | | | | 15.4 | 76/79 |
| | R-4 K | 3SIE 200 L 4 | 30.0 | 40.0 | m3/s KW % | 25.2 23.0 42 | 25.2 23.0 42 | 24.5 24.0 46 | 23.8 25.0 50 | 23.1 26.0 53 | 22.3 27.0 56 | 21.5 27.9 59 | 20.8 28.8 62 | 19.9 29.6 64 | 19.0 30.3 66 | 17.9 30.8 67 | 16.8 31.2 68 | 15.6 31.3 69 | 12.8 30.8 67 | | | | 18.2 | |

Tableau de performances pour ventilateurs à grand débit Ventomat

| | | à aspiration bilatérale | | | | | | | | | | | | | | | | | | Bruit | | | | |
|------------|----------|-------------------------|--------|------|-----------------|--------------------|--------------------|--------------------|--------------------|--------------------|--------------------|--------------------|--------------------|--------------------|--------------------|-----|--------------------|--------------------|--------------------|--------------------|-----|--------------|-------|-------|
| FAT | Ventomat | Moteur | Taille | | mbar | 2 | 3 | 4 | 5 | 6 | 7 | 8 | 90 | 100 | 110 | 120 | 130 | 140 | 160 | 180 | 200 | Pression max | Bruit | |
| N° de test | Type | Type | KW | CV | mmCE | 20 | 30 | 40 | 50 | 60 | 70 | 80 | 90 | 100 | 110 | 120 | 130 | 140 | 160 | 180 | 200 | mbar | dB(A) | |
| 1320 T | R-5 K | 3SIE 132 M4 | 7.5 | 10.0 | m3/s KW % | 18.9 8.6 44 | 17.0 9.0 57 | 14.9 9.0 66 | 12.3 9.0 69 | 9.2 8.4 65 | 1.4 6.4 16 | | | | | | | | | | | | 7.0 | 63/65 |
| 1320 K | R-5 K | 3SIE 160 MA 4 | 10.0 | 13.5 | m3/s KW % | 20.8 10.5 40 | 19.2 11.0 52 | 17.4 11.3 61 | 15.2 11.3 67 | 12.8 10.4 65 | 9.7 10.4 65 | 3.9 8.5 37 | | | | | | | | | | | 8.1 | 64/66 |
| 1320 | R-5 K | 3SIE 160 MA 4 | 11.0 | 15.0 | m3/s KW % | 21.7 11.5 38 | 20.1 12.0 50 | 18.3 12.4 59 | 16.4 12.4 66 | 14.1 12.3 68 | 11.6 11.9 68 | 7.3 10.6 55 | | | | | | | | | | | 8.6 | 65/67 |
| 1320 H | R-5 K | 3SIE 160 L 4 | 15.0 | 20.0 | m3/s KW % | 25.3 16.5 33 | 24.0 17.0 42 | 22.6 17.5 52 | 21.0 18.1 58 | 19.4 18.0 65 | 17.4 18.1 68 | 15.3 17.9 69 | 12.8 17.2 67 | 9.6 16.4 60 | 3.4 13.0 30 | | | | | | | | 11.1 | 68/70 |
| 1936 | R-5 K | 3SIE 180 M 4 | 18.5 | 25.0 | m3/s KW % | 25.7 16.7 41 | 24.5 17.7 46 | 23.2 18.6 51 | 21.9 19.4 56 | 20.5 20.1 59 | 18.9 20.7 62 | 17.3 21.1 64 | 15.4 21.3 65 | 13.2 21.1 63 | 10.6 20.4 58 | | 6.9 18.4 45 | | | | | | 12.4 | 70/73 |
| 1937 | R-5 K | 3SIE 180 L 4 | 22.0 | 30.0 | m3/s KW % | 28 19.9 37 | 26.9 20.9 42 | 25.8 21.8 47 | 24.6 22.6 52 | 23.4 23.4 57 | 22 24.1 61 | 20.6 24.7 64 | 19.0 25.1 66 | 17.3 25.3 67 | 15.4 25.3 67 | | 10.1 23.6 56 | | | | | | 13.9 | 70/73 |
| | R-5 K | 3SIE 200 L 4 | 30.0 | 40.0 | m3/s KW % | | | 30.7 32.7 38 | 29.5 33.2 44 | 28.5 34.1 50 | 27.3 34.7 54 | 25.9 35.3 63 | 24.8 35.3 66 | 23.2 35.3 66 | 21.9 35.2 67 | | 20.0 35.0 68 | 16.4 33.8 68 | 10.3 30.1 55 | | | | 17.3 | |
| | R-5 K | 3SIE 225 S4 | 37.0 | 50.0 | m3/s KW % | | | 31.4 33.0 40 | 30.5 34.3 45 | 29.5 35.5 49 | 28.4 36.3 53 | 27.3 37.0 57 | 26.2 37.7 60 | 25.0 38.4 63 | 23.8 39.0 65 | | 22.5 39.5 67 | 19.4 40.0 68 | 15.6 39.5 63 | 10.8 38.0 55 | | | 18.9 | |
| 1846T | R-6 K | 3SIE 160 MA 4 | 11.0 | 15.0 | m3/s KW % | 22.3 10.3 45 | 20.8 11.3 53 | 19.0 12.1 60 | 17.1 12.7 65 | 14.8 13.2 68 | 11.8 13.1 66 | 6.7 11.5 47 | | | | | | | | | | | 8.1 | 63/65 |
| 1846 | R-6 K | 3SIE 160 L 4 | 15.0 | 20.0 | m3/s KW % | 25.8 14.1 42 | 24.4 15.2 49 | 23.0 16.2 55 | 21.4 17.1 60 | 19.7 17.9 64 | 17.8 18.4 67 | 15.6 18.7 68 | 12.7 18.5 65 | 8.3 16.7 50 | | | | | | | | | 10.2 | 66/68 |
| 1847 | R-6 K | 3SIE 180 M 4 | 18.5 | 25.0 | m3/s KW % | 28.0 16.8 42 | 26.8 18.0 48 | 25.5 19.2 53 | 24.1 20.2 58 | 22.7 21.2 62 | 21.1 22.0 65 | 19.3 22.6 67 | 17.2 23.0 68 | 14.7 22.9 66 | 11.3 21.8 59 | | | | | | | | 11.6 | 66/70 |
| 1848 | R-6 K | 3SIE 180 L 4 | 22.0 | 30.0 | m3/s KW % | 29.8 19.3 41 | 28.7 20.6 47 | 27.5 21.7 51 | 26.2 22.8 56 | 24.9 23.8 60 | 23.4 24.7 63 | 21.8 25.5 66 | 20.1 26.1 68 | 18.1 26.4 68 | 15.7 26.3 67 | | 12.4 25.4 61 | | | | | | 12.8 | 69/73 |
| | R-6 K | 3SIE 200 L 4 | 30.0 | 40.0 | m3/s KW % | | 31.9 26.2 44 | 30.9 27.6 48 | 29.9 29.0 51 | 28.7 30.0 55 | 27.7 31.3 59 | 26.2 32.2 62 | 24.8 33.1 65 | 23.4 34.0 67 | 21.6 34.6 68 | | 19.8 34.8 68 | 15.0 31.0 63 | | | | | 15.4 | |
| | R-6 K | 3SIE 225 S4 | 37.0 | 50.0 | m3/s KW % | | 32.9 31.0 45 | 32.9 31.0 45 | 31.9 32.0 48 | 30.8 33.0 52 | 29.5 34.3 56 | 28.2 35.6 59 | 27.1 35.9 62 | 25.9 36.2 64 | 24.4 20.0 66 | | 22.8 38.7 68 | 20.9 39.0 68 | 13.0 37.5 56 | | | | 16.8 | |

Dimensions des ventilateurs à aspiration bilatérale

Types: R-2K, R-3L, R-3K, R-4K, R-5K, R-6K

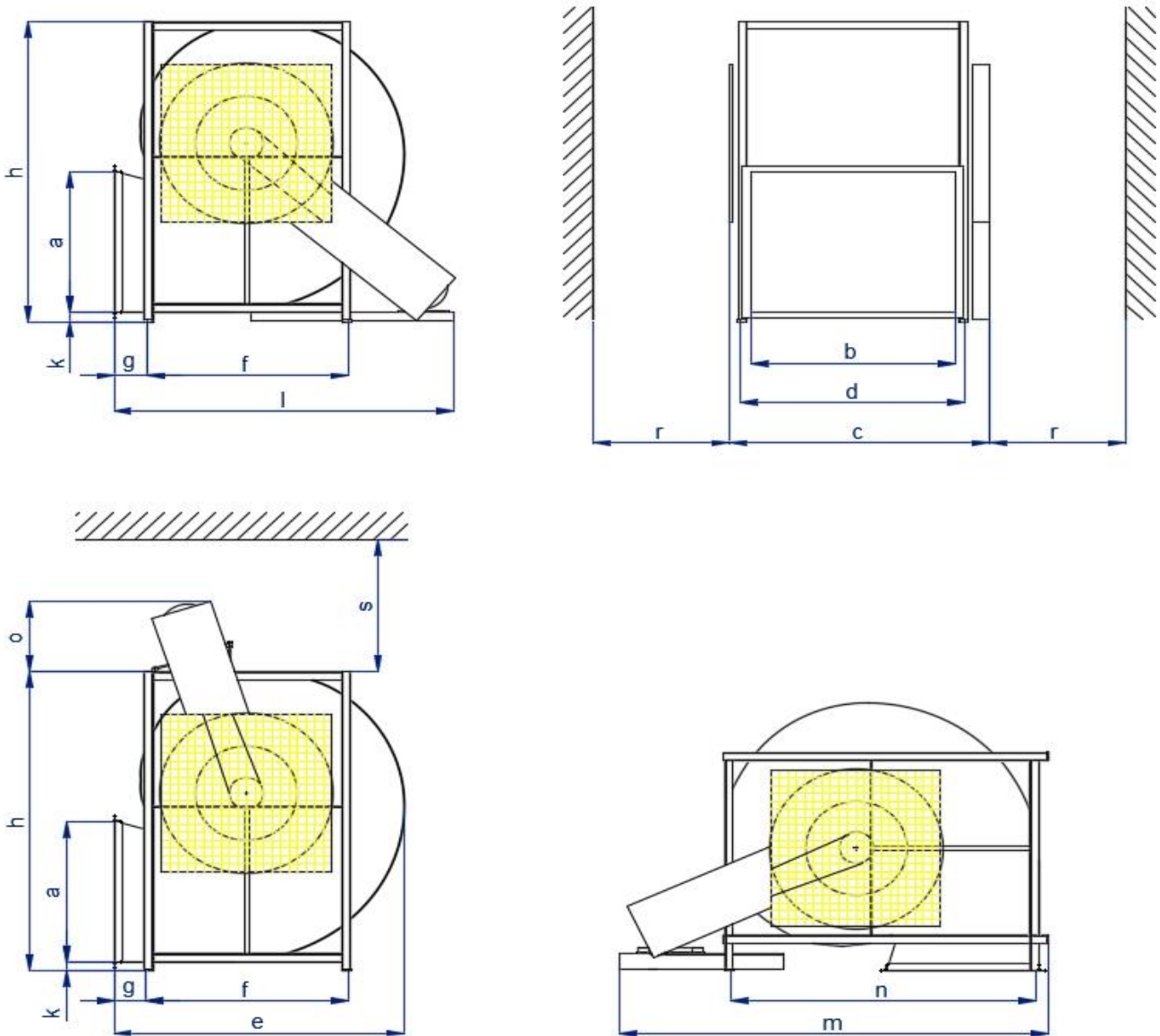

| Type | a | b | c | d | e | f | g | h | k | l à 22 kW | l 30 et 37 kW | m à 22 kW | m 30 et 37 kW | n | o | r | s | Poids env. [kg] |
|------|------|------|------|------|------|------|-----|------|----|--------------------|---------------------------|--------------------|---------------------------|------|-----|------|-----|--------------------|
| R-2K | 690 | 1210 | 1550 | 1330 | 1440 | 955 | 140 | 1730 | 60 | 1700 | | 2300 | | 1655 | 500 | 800 | 600 | 450 |
| R-3L | 890 | 1070 | 1410 | 1190 | 1710 | 1180 | 190 | 1930 | 60 | 2000 | | 2600 | | 1800 | 500 | 800 | 600 | 530 |
| R-3K | 890 | 1210 | 1550 | 1330 | 1710 | 1180 | 190 | 1930 | 60 | 2000 | 2130 | 2600 | 2600 | 1800 | 500 | 800 | 600 | 550 |
| R-4K | 1060 | 1210 | 1550 | 1330 | 1900 | 1180 | 170 | 2250 | 60 | 2000 | 2210 | 2800 | 2800 | 2050 | 500 | 800 | 600 | 750 |
| R-5K | 1150 | 1285 | 1630 | 1405 | 2040 | 1275 | 140 | 2570 | 60 | 2040 | 2270 | 3100 | 3100 | 2345 | 500 | 1000 | 600 | 820 |
| R-6K | 1220 | 1460 | 1820 | 1580 | 2040 | 1430 | 40 | 2570 | 60 | 2040 | 2270 | 3100 | 3100 | 2345 | 500 | 1000 | 600 | 950 |

toutes dimensions en mm

Dimensions des ventilateurs à aspiration unilatérale

Types: SE-1, SE, SE-B, SE-2, SE-2B, SE-2BH, SE-3, SE-3K, SE-3G, SE-4

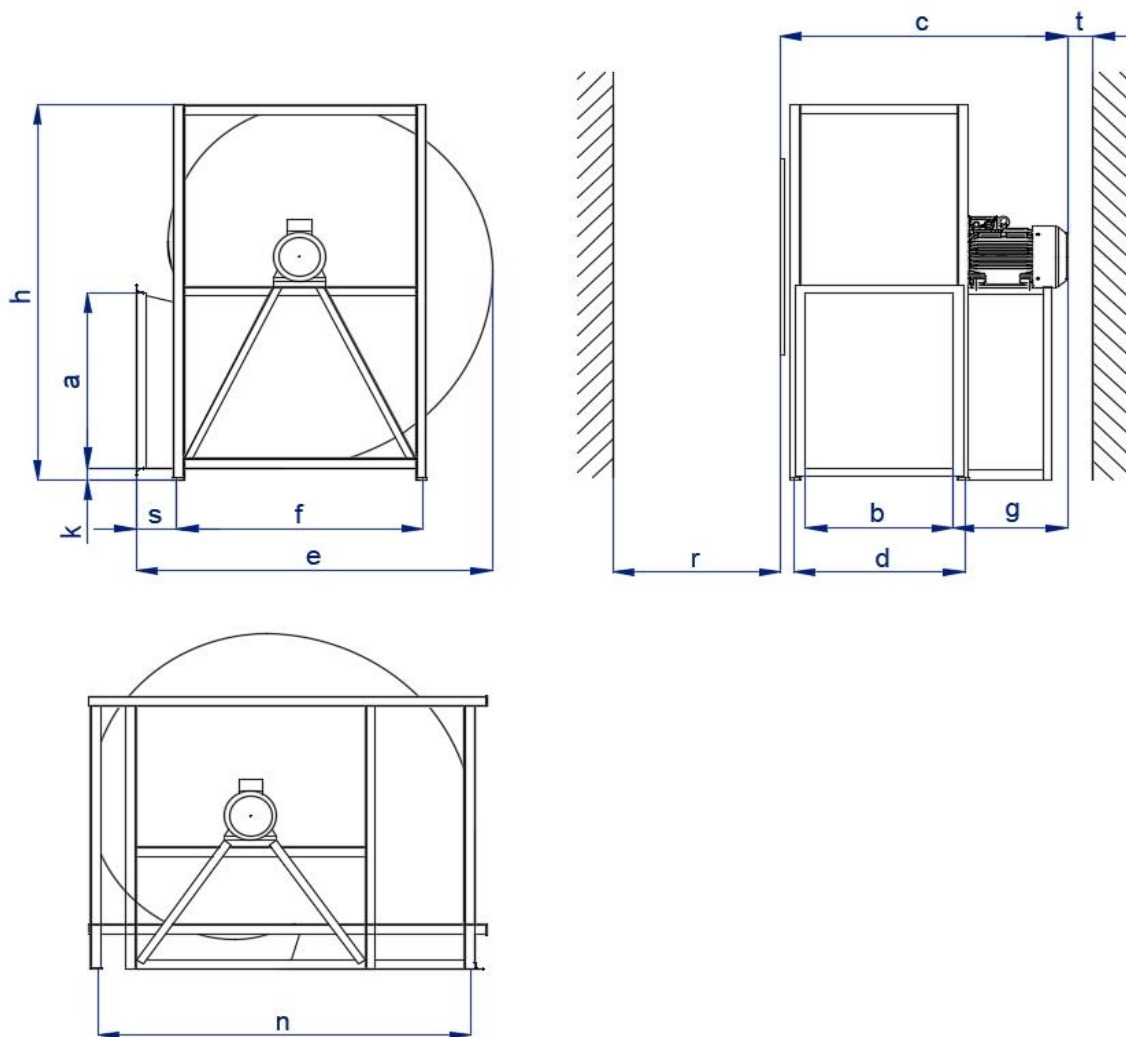

| Type | a | b | c | d | e | f | g | h | k | n | r | s | t | poids env. [kg] |
|-------------------------|------|-----|------|-----|------|------|-----|------|-----|------|------|-----|-----|-----------------|
| SE-1-60 | 563 | 176 | 620 | 300 | 1065 | 805 | 380 | 1370 | 105 | | 600 | 30 | 200 | 150 |
| SE-1-100 | 563 | 216 | 660 | 340 | 1056 | 805 | 380 | 1370 | 105 | | 600 | 30 | 200 | 150 |
| SE SE-B | 640 | 460 | 1030 | 580 | 1450 | 950 | 460 | 1740 | 60 | 1655 | 800 | 140 | 200 | 260 |
| SE-2 SE-2B SE-2BH | 640 | 580 | 1150 | 705 | 1450 | 950 | 460 | 1740 | 60 | 1655 | 800 | 140 | 200 | 270 |
| SE-3 SE-3K SE-3G | 970 | 710 | 1310 | 830 | 1710 | 1180 | 550 | 1930 | 60 | 1800 | 800 | 190 | 200 | 380 |
| SE-4 | 1060 | 710 | 1500 | 830 | 1900 | 1185 | 630 | 2250 | 60 | 2050 | 1000 | 170 | 200 | 450 |

toutes dimensions en mm

Dimensions des ventilateurs à aspiration unilatérale à entraînement par courroie

Types: RE-2, RE-3, RE-4

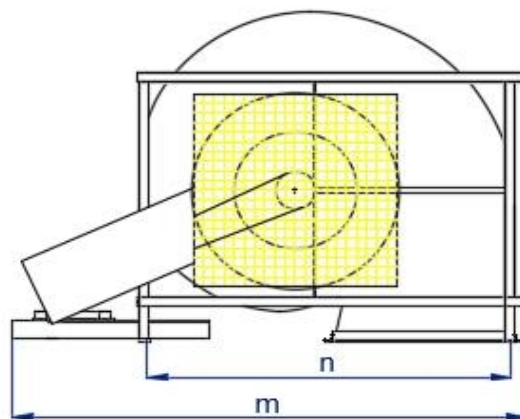
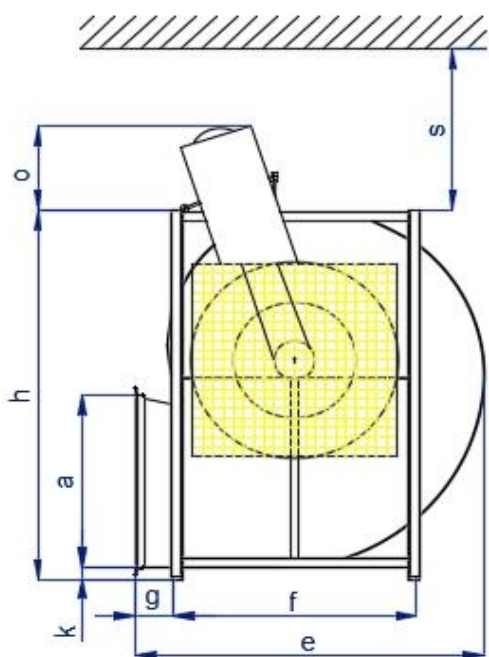
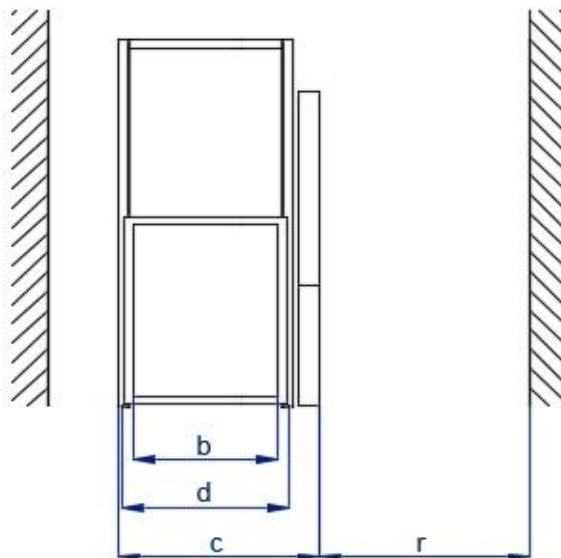
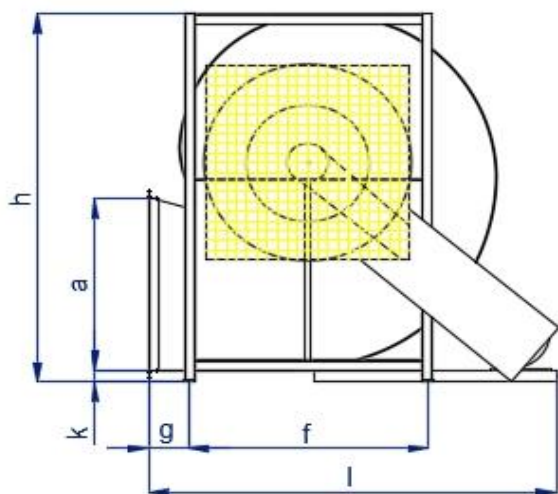

| Type | a | b | c | d | e | f | g | h | k | l | m | n | o | r | s | poids env. [kg] |
|------|------|-----|------|-----|------|------|-----|------|----|------|------|------|-----|-----|-----|-----------------|
| RE-2 | 640 | 580 | 925 | 705 | 1440 | 955 | 140 | 1730 | 60 | 1700 | 2300 | 1655 | 500 | 800 | 600 | 370 |
| RE-3 | 970 | 710 | 1050 | 830 | 1710 | 1180 | 190 | 1930 | 60 | 2000 | 2600 | 1800 | 500 | 800 | 600 | 450 |
| RE-4 | 1060 | 710 | 1050 | 830 | 1900 | 1180 | 170 | 2250 | 60 | 2000 | 2800 | 2050 | 500 | 800 | 600 | 600 |

toutes dimensions en mm

Position de l'enveloppe et montage du moteur

Ventilateurs à aspiration bilatérale

0° - U

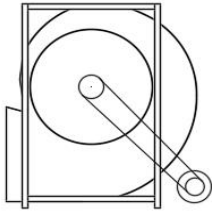

90° - U

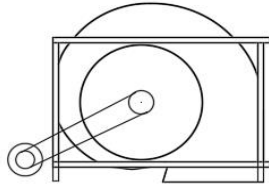

180° - U

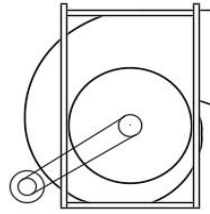

270° - U

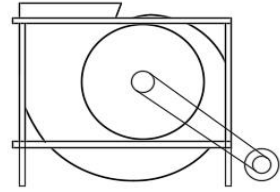

0° - O

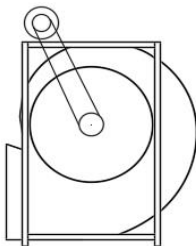

90° - O

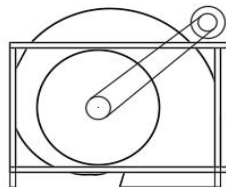

180° - O

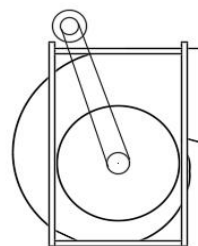

270° - O

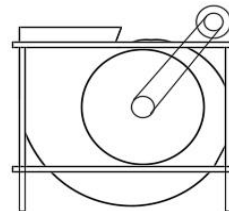

Ventilateurs à aspiration unilatérale

0° - L

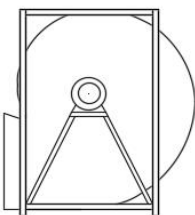

90° - L

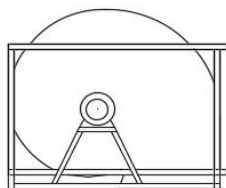

180° - L

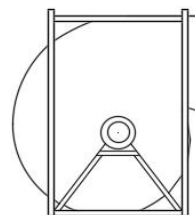

270° - L

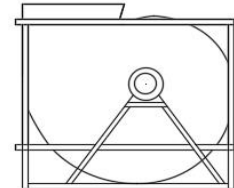

0° - R

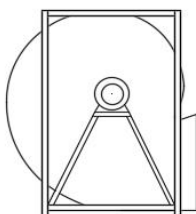

90° - R

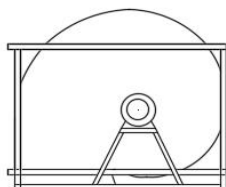

180° - R

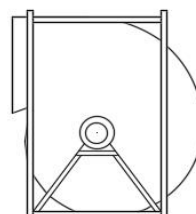

270° - R

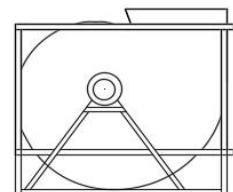



Karl Barth AG
Unterdorf 27
CH- 8421 Dättlikon

Tel. +41 52 301 00 13
E-mail info@kbarth.ch
Internet www.kbarth.ch

Version: 20.09.2022